

SMART SHOWER FOAMING MACHINE USER MANUAL

WOODBRIDGE[®]

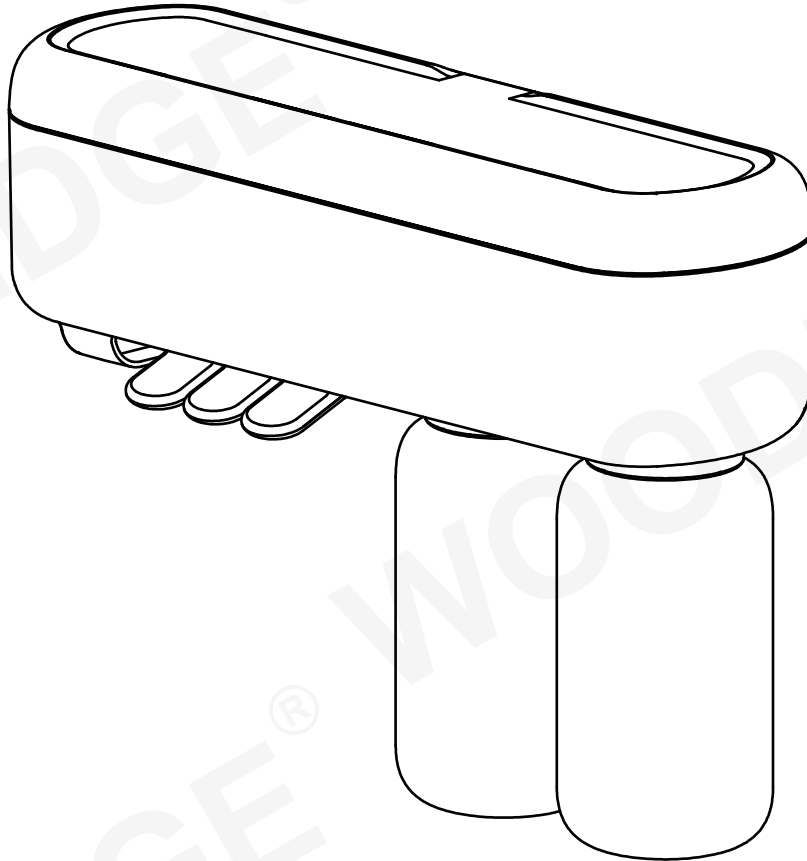

To Activate
Warranty



RoHS

Customer Service Phone: 562-229-0088. (Monday - Friday 9 AM - 5 PM Pacific Standard Time)

Or Email: help@woodbridgebath.com

Package Contents:

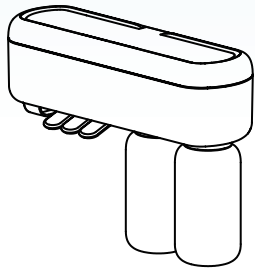

Machine*1

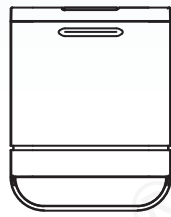

Battery pack * 1

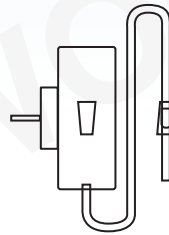

Battery charger * 1

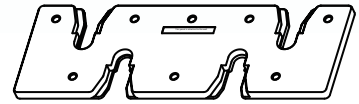

Punch hook * 1

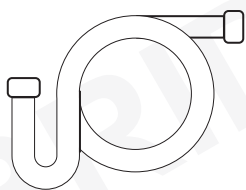

Shower Hose * 2

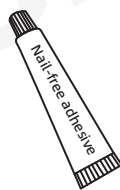

Nail-free adhesive*1

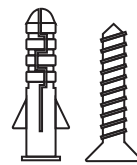

Screw accessories
package * 1
(including expansion sleeve * 3,
screw * 3)

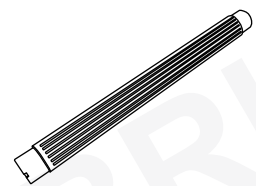

Suction tube* 2

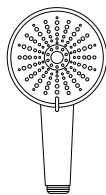

Handheld shower *1

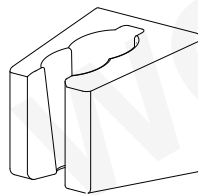

Shower clamp *1
(random color)

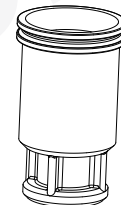

Mixing tube *1

Product specifications:

| | |
|------------------------------------|-------------------|
| Product model | SF-01-WH/SF-04-GR |
| Rated voltage of the power adapter | 100-220V~50/60Hz |
| Rated voltage | DC 12.6V |
| Rated power | 18W |
| Net weight | 7lb |
| Dimensions | 13x4.7x9.4in |
| Recommend water pressure | 29-73 psi |

Installation instructions:

Remove the machine and accessories from the package

Step 1 - Choose a wall-mounting location indoors

- The length of the power adapter cable is 1.5 meters. Pay attention to the distance between the wall-mounted position and the power outlet. If the length of the built-in power cord is insufficient, an extension power cord can be used.
- It is recommended to stay away from the showerhead and avoid direct flushing of water sources onto the body.
- The installation height is 1.4 meters from the bottom of the body to the ground. In practice, users should consider the bathroom space and ease of operation when choosing the installation location.

Step 2- Install the Wall Hook

Two mounting options are available.

Option A: Drill Installation (Recommended)

- Drill holes using a 6 mm drill bit.
- Insert the expansion anchors into the holes.
- Secure the hook to the wall using the provided screws.

This method provides the most secure installation.

Option B: Adhesive Installation (No Drilling)

Suitable for smooth, hard wall surfaces such as ceramic tiles.

- Clean dust and grease from the wall surface.
- Apply the nail-free adhesive to the back of the hook.
- Press the hook firmly onto the wall in a horizontal position.
- Use tape to hold it in place and allow 24 hours for curing before hanging the unit.

Note: Adhesive mounting may weaken over time. Drill mounting is recommended for long-term use.

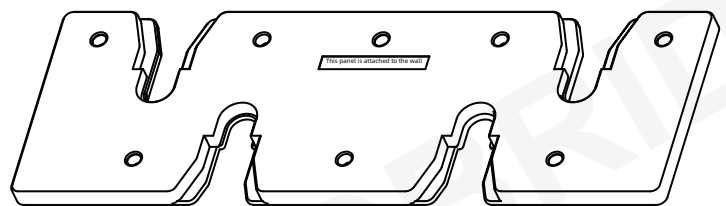

▲ Punching hooks

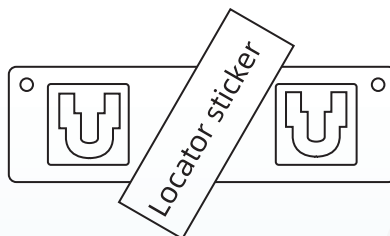
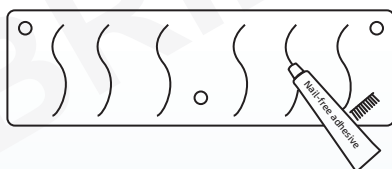

◀ Adhesive free bonding



Warning Sign:

1. Please choose the installation method according to the actual wall material. Pay attention to distinguish the direction of the hook before the positive and negative paste.
2. It is recommended to use perforated hooks for reliable fixation. Adhesive bonding without nails may cause aging and failure, and the company will not be responsible for any losses

Step 3 - Pipe Installation Instructions

The white rubber plug at the entrance and exit of the main unit is taken out, and the machine will be inspected and tested before leaving the factory. There will be water residue in the main unit. This is normal.

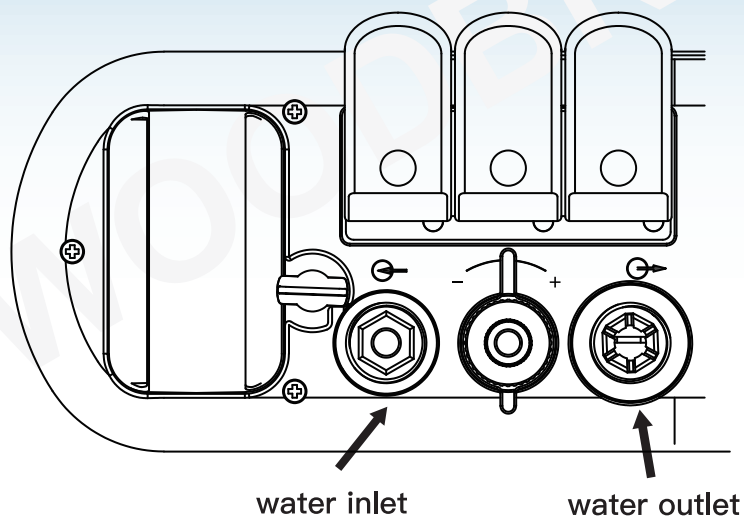

After hanging the shower on the wall, remove the original shower, and connect the special hand-held shower in the package to the water outlet of the shower. Connect the bath hose in the package to the shower and hot water. Device/shower platform.

Connect the shower inlet

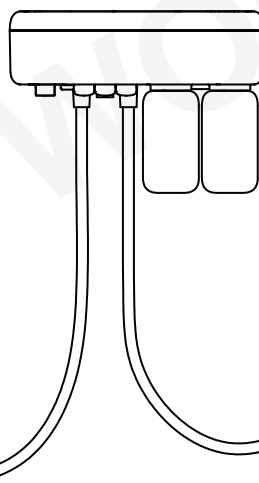

Connect the shower outlet

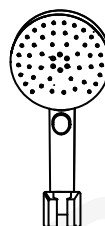

Step 4 - Install and Charge the Battery Pack

- Turn the knob on the right side of the unit to unlock the battery compartment.
- Insert the battery pack into the main unit in the correct orientation. When the battery pack is installed correctly, you will hear a sound, indicating that the unit has powered on.

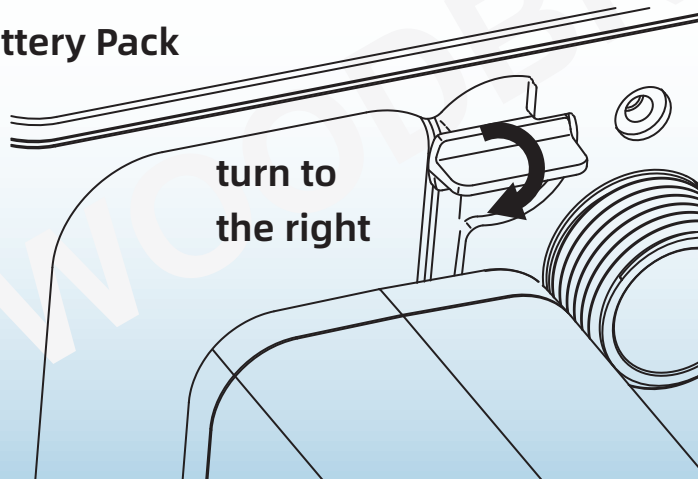

turn to the right

- Turn the knob back to lock the compartment.

Before first use, remove the battery pack and charge it using the battery charger. The indicator light on the adapter will turn green when the battery is fully charged.

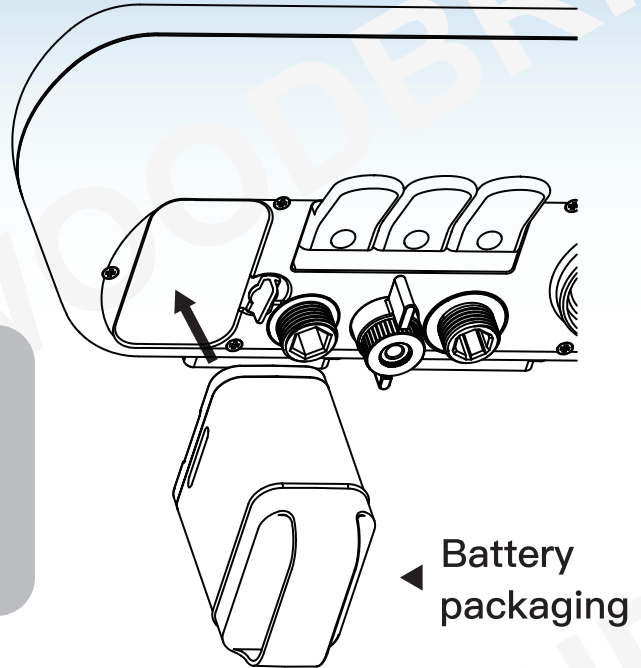

Warning Sign:

1. Before discarding the appliance, the battery must be removed from the appliance;
2. When taking out the battery, the appliance must be powered off;
3. The battery should be disposed of safely.

Step 5 - Add Bath Lotion and Shampoo

Unscrew the liquid bottle, pour shampoo and bath lotion into the two liquid bottles respectively according to the text instructions, and then screw the liquid bottles into the corresponding positions. The capacity of a single liquid bottle is 500ml.

Important Notice

Do not use bath or body products that contain fine sand particles or flower petals. Such products may clog the pipes and cause equipment malfunction.

It is recommended to use shower gel or shampoo without any solid additives.

Suction Tube Installation

This product comes with two suction tubes. Each tube has two different ends: one flat end (up) and one grooved end (down) . When installing, insert the grooved end downward into the liquid bottle.

The grooves allow a small amount of air to enter during suction, enabling the liquid to be drawn properly into the system. If the flat end is placed downward, it may seal against the bottom of the bottle, preventing air from entering and stopping the liquid from being drawn.

Please ensure the suction tube is installed in the correct direction to maintain proper operation.

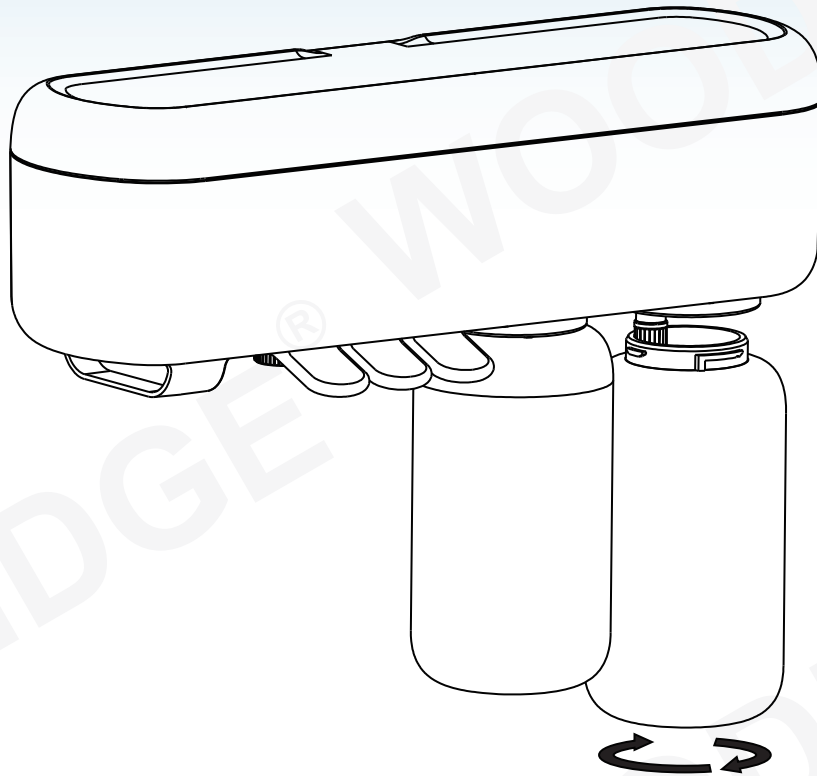

Rotating bottle body

Step 6 - Foam Adjustment

The unit is pre-calibrated before leaving the factory. If the foam density is not suitable after installation, you can adjust the knob at the bottom of the unit to change the mixing ratio of water and shampoo/body wash. This allows you to control the foam density.

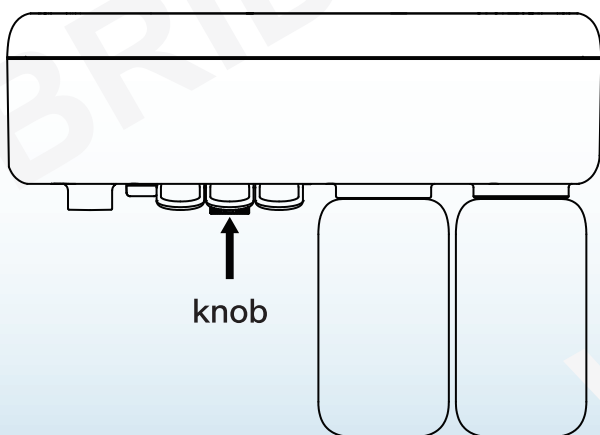

knob

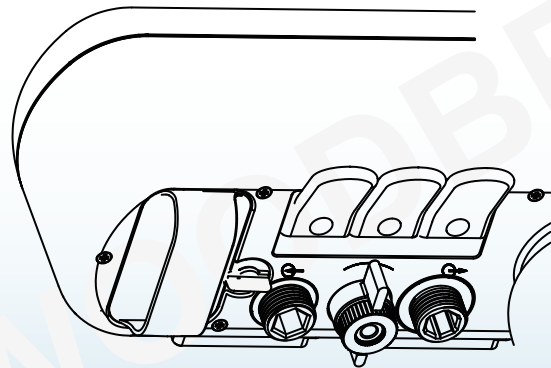

Light Foam Rich Foam

Adjust the knob to control foam density

Function Description

When you use it for the first time, you need to turn on the functions of shampoo and shower gel twice separately to ensure that the liquid is pumped into the internal pipeline to foam normally.

- Turn on the shower water valve to begin use. The buttons located at the bottom of the device correspond to different functions. The first button activates the body wash dispensing function. Please do not press two or more buttons at the same time, as this may affect normal operation.
- After using the foaming function, it is recommended to activate the clean water mode to rinse the shower hose and remove any remaining foam inside the shower head. This helps keep the internal tubing clean and ensures optimal performance for the next use.

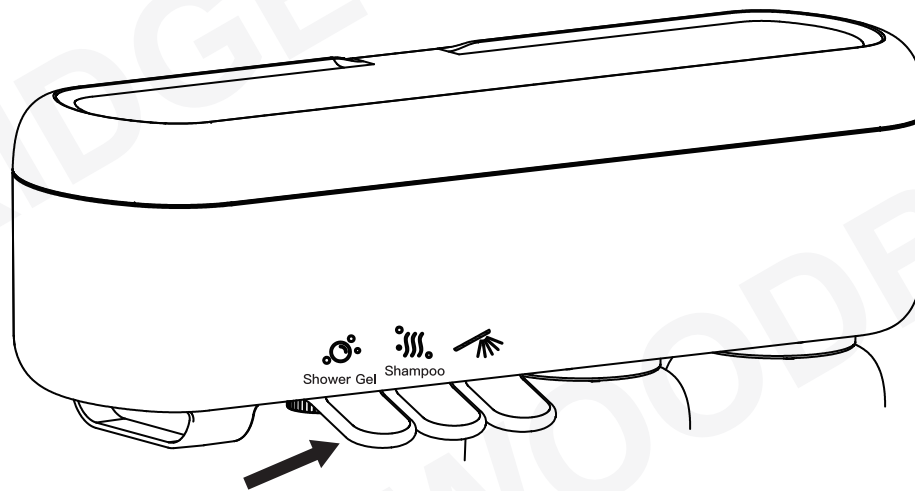

- If using a gas water heater, it is recommended to open the gas heater auxiliary drain valve when using the foaming function to avoid flame failure and cold water output.

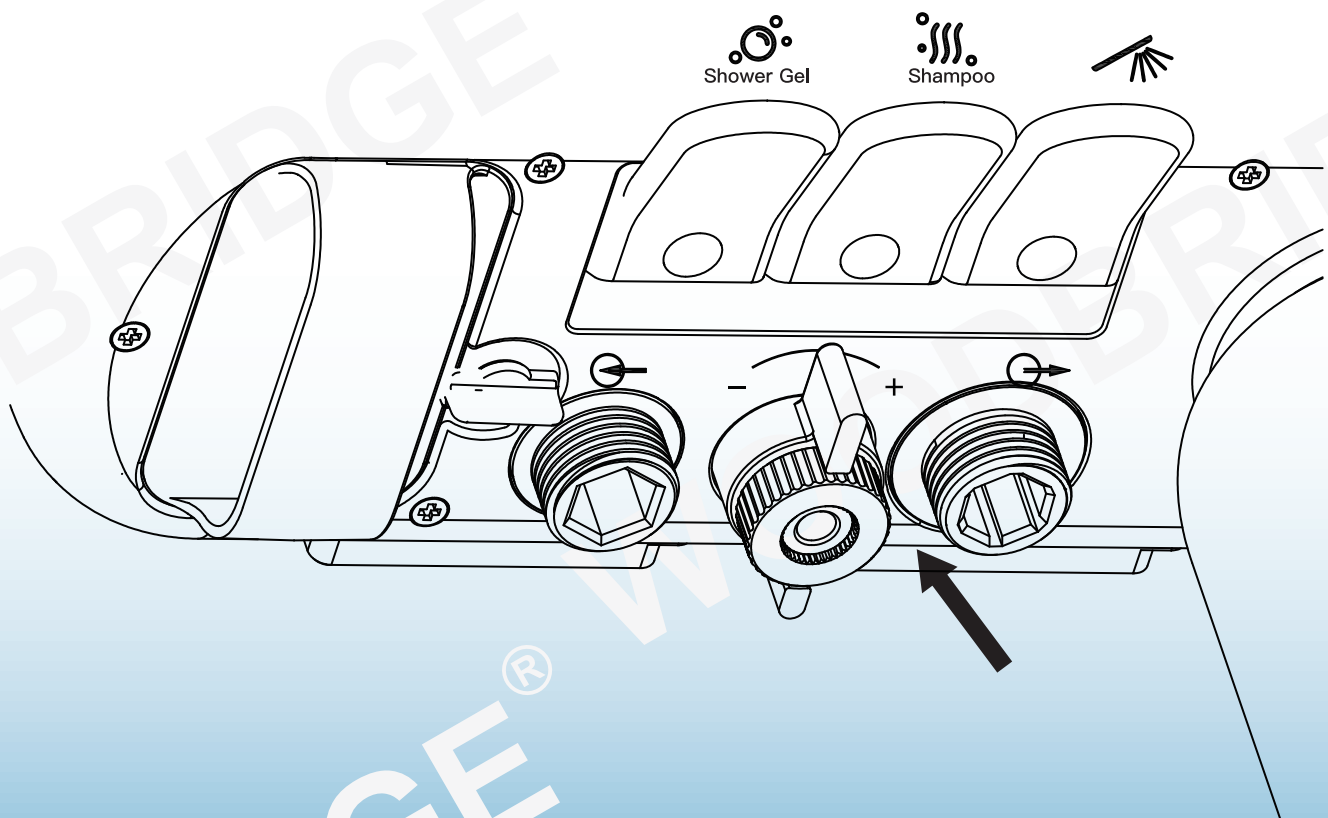

Filter Maintenance and Cleaning

- After a period of use, the foaming filter inside the mixing tube needs to be removed and cleaned.
- Remove the outlet connector nut, take out the mixing tube, remove the built-in foaming filter, and rinse it directly with clean water.
- Note: The foaming filter consists of multiple stacked pieces; please install them one by one.

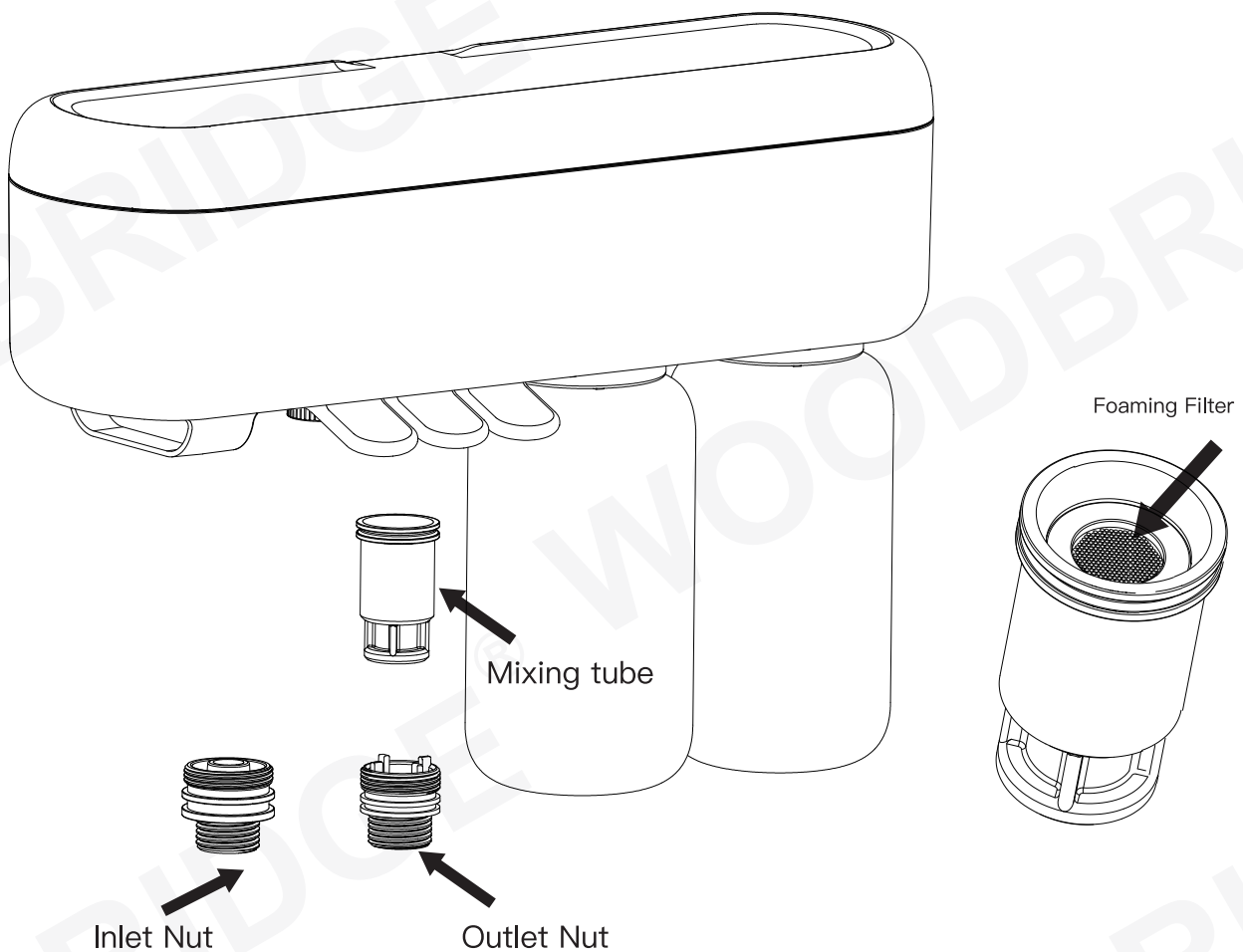

Warning Sign:

The duration of bubbles is a preset fixed value, which cannot be adjusted by itself. In the process of use, when the foaming amount can meet the actual use needs, the foaming process can be terminated by turning the knob to the clean water gear.

Woodbridge warrants the following products as listed below to be free from defects in material and workmanship, subjected to the limitations set forth in this limited warranty.

- Bathtub, Whirlpool/Air Bubble Massage Tub, Cold Plunge, Wooden Tub: 1 Year limited to be free of defects in material and workmanship.
- Sauna room and Sauna Tent: 1 Year limited to be free of defects in material and workmanship.
- Toilet and Bidet: 1 Year limited to be free of defects in material and workmanship.
- Faucet: 1 Year limited to be free of defects in material and workmanship.
- Vanity and Vanity Top: 1 Year limited to be free of defects in material and workmanship.
- Granite, Marble, Engineered Quartz Vanity Top: 1 Year limited to be free of defects in material and workmanship.
- Medicine Cabinet, LED Mirror: 1 Year limited to be free of defects in material and workmanship.
- Stainless Steel Sink: 1 Year limited to be free of defects in material and workmanship.
- Solid Surface Shower Wall Panel, SMC Shower Base: 10 Years limited warranty to be free from material defects.
- Drain Cover and PVC Drain: 1 Year limited to be free of defects in material and workmanship.
- Shower Door: Lifetime warranty on glass components and 1 Year limited on other hardware.
- Smart Shower Foaming Machine: 1-year limited to be free of defects in material and workmanship under normal use; 3-month limited for commercial or heavy-duty use.

This limited warranty is non-transferable and only applies to products purchased and installed in the United States and Canada

This limited warranty excludes all industrial, commercial and business usage. Proof of purchase (original sales receipt) from the original purchaser, Description and pictures of defect, model number or model description must be provided to Woodbridge Bath for all warranty claims and Woodbridge Bath IS NOT responsible for labor cost, removal or installation costs.

This limited warranty shall not apply to goods which have been subject to accident, negligence, improper installation, product abuse, product misuse, or use of cleaners containing abrasives, alcohol or other organic solvents, whether performed by a contractor, service company, or yourself, are excluded from this warranty.

This warranty does not cover surface damaged caused by use of chemicals that break through or dissolve the surface finish or damage caused by the accidental dropping of sharp or heavy objects. Improper care and use of abrasive cleaners and will void the warranty.

During this limited warranty period if a malfunction occurs and after inspection it is determined that a defect developed during normal use, Woodbridge reserves the right to take any of the following actions at its discretion:

- (1) repair or replace the defective part(s) or product(s) at cost**
- (2) issue a refund of the original purchase price of the product(s) (Valid within 30 days from the date of purchase)**
- (3) issue a credit to be applied toward the purchase of a new product. Shipping or delivery charges may apply. Whether such charges are required, and the amount and conditions under which they apply, shall be determined solely at the discretion of Woodbridge.**

Caution:
NEVER use cleaners containing abrasives, ammonia, bleach, acids, waxes, alcohol, solvents or other products not recommended for chrome finishes. Doing so will void the warranty.
Woodbridge strongly recommends installation by a licensed and insured professional to ensure proper performance and safety.

RESPONSIBILITIES OF OTHERS

Inspecting the unit prior to installation is the responsibility of the installer or building contractor who acts on behalf of the user. They are responsible for ensuring the unit is free of defect or damage. Notices are placed on the unit and on the shipping carton advising the installer of this responsibility. In the event of a problem, the unit must not be installed. Woodbridge is not responsible for failures or damage that could have been discovered, repaired, or avoided by proper inspection and testing prior to installation.

Damage occurring in transit is the responsibility of the carrier. The user or installer MUST open the crate and inspect the unit for damage when it is delivered. If damage is discovered, it must be reported immediately to the seller and the carrier in writing, and an inspection requested. Failure of the carrier to respond should be reported to the seller and the carrier. Your freight claims should be filed promptly thereafter.

This limited warranty does not cover any liability for consequential or incidental damages, all of which are hereby expressly disclaimed, or the extension beyond the duration of this limited warranty of any implied limited warranties, including those of merchantability or fitness for an intended purpose.

DISCLAIMER

Except as expressly provided, there shall be no warranty or obligation, express or implied, oral or statutory. No dealer or other person has the authority to make any warranties or representations concerning or its products. In no event shall be held responsible for any such warranties or representations.

Some states/provinces do not allow limitations on how long an implied warranty lasts, or the exclusion on limitation of special, incidental or consequential damages, so these limitations and exclusions may not apply to you. This warranty gives you specific legal rights, you may also have other rights which vary from state/province to state/province.

To obtain warranty and replacement parts, please send e-mail to help@woodbridgebath.com with the original receipt information, Woodbridge will determine whether to repair or replace your product, issue a refund or issue a credit.

IMPORTANT!

DO NOT USE: Abrasive cleaners such as: acid, ammonia, bleach, and similar solutions. Use of such solutions may cause corrosion, finish peeling, and/or dull the surface.

DO NOT USE: Abrasive sponges or cloth. Never use steel, wool, or wired brushes that will permanently scratch the surface.

Retain these installation instructions for future reference!

Thank you for using WOODBRIDGE® products!

WOODBRIDGE®

California (Norwalk) Centre de distribution
15600 Blackburn Ave, Norwalk, CA 90650

New Jersey (Somerset) Centre de distribution
635 Pierce St, Somerset, NJ 08873

Floride (Orlando) Centre de distribution
13645 S Orange Ave, Orlando, FL 32824

Canada (Ontario) Centre de distribution
615 Orwell Street, Unit C, Mississauga, ON L5A2W4, Canada

**SCAN
ME**

**To Activate
Warranty**



Please don't hesitate to contact us if you have any questions or concerns.

Customer Service Phone: 562-229-0088. (Monday - Friday 9 AM - 5 PM Pacific Standard Time)

Or Email: help@woodbridgebath.com

